

WHEEL LOADER ZWL55G



ZOOMLION

WHEEL LOADER ZWL55G

	Description	Standard	High Dump
Dimensions	Overall Height (Max. Bucket Lifting)	5275 mm	5637 mm
	Ground Height of Boom Lower Pin	4119 mm	4520 mm
	Dumping Height at 45° Dumping Angle	3060 mm	3458 mm
	Dumping Distance at 45° Dumping Angle	1280 mm	1230 mm
	Bucket Angle at Carry	48°	46°
	Bucket Angle at Ground	45°	42°
	Digging Depth	50 mm	50 mm
	Bucket Angle - Max. Lifting	53°	50°
	Bucket Dumping Angle	45°	45°
	Carry Height	400 mm	400 mm
	Min. Ground Clearance	409 mm	409 mm
	Center Line of Front Axle to Hitch	1615 mm	1615 mm
	Wheelbase	3230 mm	3230 mm
	Overall Length	8090 mm	8230 mm
	Departure Angle	32°	32°
	Height to Top of Cab	3400 mm	3400 mm
	Overall Width over Bucket	3000 mm	3000 mm
	Min. Turning Radius over Bucket	7170 mm	7280 mm
	Min. Turning Radius over Tires	6537.5 mm	6537.5 mm
	Steering Angle - Left/Right	35°	35°
	Width at Tread Center	2240 mm	2240 mm
	Overall Width over Tires	2835 mm	2835 mm

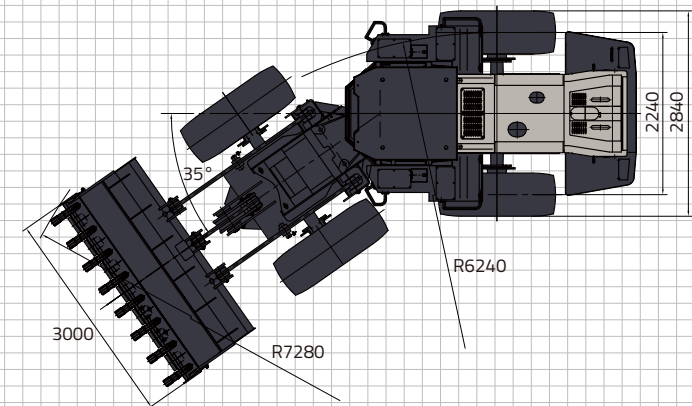
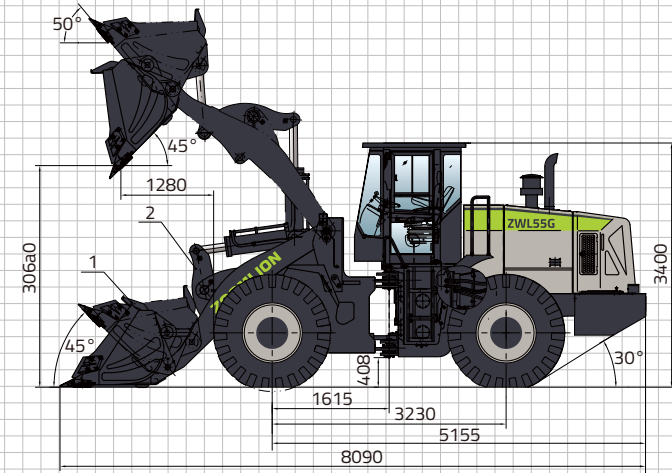

Technical Parameters				Configuration	Optional		
Basic	Bucket Capacity	3.0 m ³	Drive Train	Transmission Type	Planetary Transmission	WEICHAI Engine	Pilot Working Control
	Rated Payload	5000 kg		Shift Type	Mechanical Powershift Control	LONKING Transmission	High Dumping Boom
	Operating Weight	16800±300 kg		Transmission Pressure	1.2-1.5 MPa	Mechanical Powershift Control	Oil-bath Air Filter
	Traction Force	155±3 kN		Torque Converter Type	Single-stage, Twin Turbine, 4 Elements	LONKING Axles (Dry type)	Radial Tire
	Breakout Force	170±3 kN		Drive Axle	Rigid (Front) & Oscillating (Rear)	Mechanical Powershift Control	3rd Spool
	L×W×H, mm	8015 (8230) ×3000×3380		Rear Axle Oscillation	±10°	Air Caliper Brake System	Sliding Cab Window
Engine	Manufacturer/Model	Weichai/WD10G220E21	Hydraulic System	Differential	Conventional	ROPS & FOPS Cab	Electric Heating Rear Window
	Rated Power/Speed	162 kW / 2200 rpm		Main Reducer	Spiral Bevel, 1-stage Reduction	Mechanical Instrument	Lockable Oil Tank Cap
	Max. Torque/Speed	860 N·m / 1400-1600 rpm		Final Reducer	Planetary Reduction	Fan Heater	Backup camera
	Bore × Stroke	126×130 mm		Tire	23.5-25 L-3 16P R TT		Radio/MP3
	No. of Cylinders Displacement	6 / 9.726 L		Travel Speed - Forward	13 / 36 km/h		Bucket (3 Piece Cutting Edges)
	Air Filter	Three Stage Filtration Air Filter		Travel Speed - Reverse	16 km/h		Rock Bucket (2.7 m ³)
	Alternator	70 Amp		Type	Mechanical Powershift Control		Enlarged Bucket (3.5 m ³)
	Battery	2-24 V / 120 Ah		Gear Pump	220 L/min · 2200 rpm		Coal Bucket (4.2 m ³)
Brake System	Starting Motor	24 V / 7.5 kW	Oil capacity	Distribution Valve	2 Spool		Log Grapple
	Service Brake	Air-over-hydraulic Caliper Brake System		System Pressure	16 MPa		Grass Grapple
	Pressure	0.70 - 0.78 MPa		Cycle Time (Sec)	11		Side Dumping Bucket (2.5 m ³)
	Parking Brake	Air Caliper Brake System		Fuel Tank Capacity	285 L		Marble Fork
Steering System	Emergency Brake	Air Caliper Brake System	Hydraulic Oil Refill Capacity	265/270 (3rd Spool) L		Cargo Fork	
	Type	Hydraulic Load Sensing Steering System	Engine Oil Refill Capacity	20 L		Quick Hitch Coupler	
	Gear Pump	176 L/min · 2200 rpm	Transmission Oil Refill Capacity	46 L		Quick Hitch Bucket	
	System Pressure	15 MPa	Front Axle/Rear Axle	28 L / 28 L		Quick Hitch 4-in-1 Bucket	
	Steering Cylinder Type	Double Cylinders Acting				Quick Hitch Snow Blade	
	Steering Angle	±35°					

ZOOMLION

Zoomlion Heavy Industry Science & Technology Co.,Ltd.

Add: No.361, South Yinpen Road 361, Changsha, HunanProvince, P.R.China 410013

Email: earthmoving@zoomlion.com

Copyright©2023 Zoomlion. All rights reserved. Reproduction and copying of any part of contents is not allowed for any purposes without Zoomlion's approval.

Note: Materials and specifications are subject to change without notice. Featured machines in photos may include additional equipment.



en.zoomlion.com



[zoomliontech](#)



[zoomliontech](#)



[zoomlion](#)



[zoomliontech](#)



[ZOOMLION Tech](#)